

4K UHD PTZ Camera

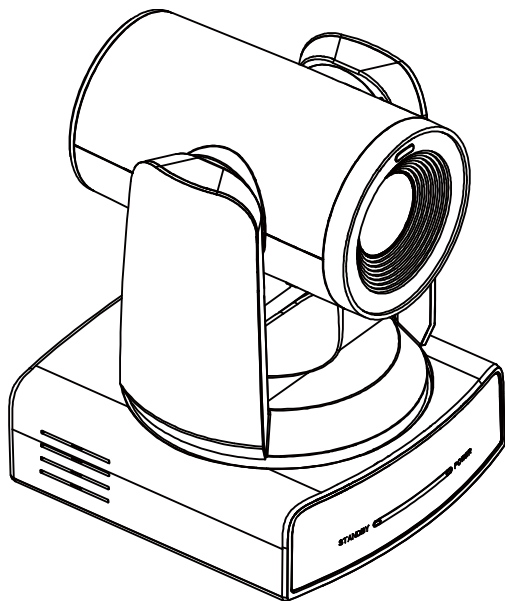

User Manual

English (V1.0)



Copyright

All contents of this manual, whose copyright belongs to our corporation, cannot be cloned, copied or translated without the permission of our corporation.

Notice

Product specifications and information which were referred to in this document are for reference only. We may change, delete, or update any content at any time and without prior notice.

FCC NOTICE (Class A)



This product complies with Part 15 of the FCC Rules. The operation is subject to the following two conditions: (1) this device may not cause harmful interference, and (2) this device must accept any interference received, including interference that may cause undesired operation.



Note

This product has been tested and found to comply with the limits for a Class A digital device, pursuant to Part 15 of the FCC Rules. These limits are designed to provide reasonable protection against harmful interference in a residential installation. This equipment generates uses and can radiate radio frequency energy and, if not installed and used in accordance with the instructions, may cause harmful interference to radio communications. However, there is no guarantee that interference will not occur in a particular installation. If this equipment does cause harmful interference to radio or television reception, which can be determined by turning the equipment off and on, the user is encouraged to try to correct the interference by one or more of the following measures:

- Reorient or relocate the receiving antenna.
- Increase the separation between the equipment and receiver.
- Connect the equipment into an outlet on a circuit different from that to which the receiver is connected.
- Consult the dealer or an experienced radio/television technician for help.

Class A ITE

Class A ITE is a category of all other ITE which satisfies the class A ITE limits but not the class B ITE limits. Such equipment should not be restricted in its sale but the following warning shall be included in the instructions for use:



Warning

Operating this equipment in a residential environment may cause radio interference.

European Community Compliance Statement (Class A)



This product is herewith confirmed to comply with the requirements set out in the Council Directives on the Approximation of the laws of the Member States relating to Electromagnetic Compatibility Directive

2014/30/EU.

Catalogue

1	Safety Precautions	1
2	Packing List	1
3	Product Connection	1
4	Video Format	3
5	About Product	3
5.1	Features	3
5.2	Specifications	5
5.3	Interface and Switch	7
5.4	Dimension	7
5.5	Installation	8
5.6	Remote Control	10
6	GUI Settings	12
6.1	MENU	12
6.2	EXPOSURE	12
6.3	COLOR	13
6.4	IMAGE	14
6.5	P/T/Z	14
6.6	NOISE REDUCTION	14
6.7	SETUP	14
6.8	TRACKING CONFIG	15
6.9	COMMUNICATION SETUP	15
6.10	RESTORE DEFAULT	16
7	WEB Settings	16
7.1	Access Camera	16
7.2	Control Camera	17
7.3	Video Settings	19
7.4	Tracking Settings	19
7.4.1	Presenter	19
7.4.2	Zone	20
7.5	Image Settings	21
7.5.1	Exposure	21
7.5.2	Color	21
7.5.3	Image	21

7.5.4 PTZ	22
7.5.5 Noise	22
7.6 Audio Settings	22
7.7 System Settings	23
7.7.1 Initialize	23
7.7.2 User	23
7.7.3 U Disk Record	23
7.7.4 Online Upgrade	23
7.8 Network Settings	23
7.8.1 Lan	23
7.8.2 Port	24
7.8.3 RTMP(S)	24
7.8.4 SRT Settings	25
7.8.5 RTSP	25
7.8.6 ONVIF	25
7.8.7 Multicast	25
7.8.8 FreeD	25
7.8.9 NTP	25
7.9 Overlay	25
7.10 Device Information	26
8 AI Tracking	26
8.1 Web Control	26
8.2 Remote Control	38
9 Troubleshooting	40

1 Safety Precautions

- During the installation and use of the equipment, all electrical safety regulations of the country and region of use must be strictly observed.
- Please use the power adapter that comes standard with this product.
- Please do not connect multiple devices to the same power adapter (exceeding the capacity of the adapter may generate excessive heat or cause a fire).
- Do not rotate head of the camera by hand, otherwise it may cause mechanical failure.
- When installing this product on a wall or ceiling, secure the device securely. When installing, make sure that there are no obstacles within the rotation range of the gimbal; do not turn on the power until all installations are completed.
- To avoid heat build-up, keep ventilation around the device smooth.

- If the device emits smoke, smells, or makes noises, please turn off the power immediately and unplug the power cord, and contact the dealer in time.
- This device is not waterproof, please keep the device dry.
- This product has no user serviceable parts, damage caused by disassembly by the user is not covered by the warranty.



Specific frequencies of electromagnetic field may affect the image of the camera!

2 Packing List

Name	Quantity
Camera	1
Remote Control	1
Power Adapter	1
Power Cable	1
RS232 Cable	1
USB Cable (Optional)	1
User Manual	1

3 Product Connection

- 1) Please check connections are correct before starting.

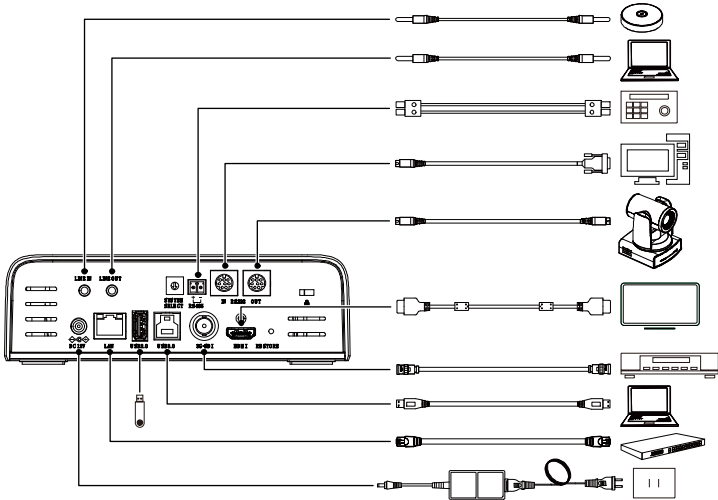

The schematic diagram is for reference only. Please refer to the actual application scenario for product connection.

2) After the camera is powered on, it starts to initialize, right up to the limit position, and then both horizontal and vertical go to the middle position, the motor stops running, and the initialization is completed.

(Note: If preset 0 is saved, PTZ will be move to preset 0)

of the chip, the camera is equipped with advanced AI algorithms to realize monocular humanoid tracking, which can realize automatic tracking of scenes such as education, conferences and live broadcasts.

4 Video Format

HDMI		SDI	
0	1080P60	0	1080P60
1	1080P50	1	1080P50
2	1080I60	2	1080I60
3	1080I50	3	1080I50
4	1080P30	4	1080P30
5	720P60	5	720P60
6	1080P29.9 7	6	1080P29.9 7
7	1080I59.94	7	1080I59.94
8	1080P59.9 4	8	1080P59.9 4
9	720P59.94	9	720P59.94
A	4KP29.97	A	1080P29.9 7
B	4KP59.94	B	1080P59.9 4
C	4KP25	C	1080P25
D	4KP30	D	1080P30
E	4KP50	E	1080P50
F	4KP60	F	1080P60



Notice

After switching the video format, you need to restart the camera before taking effect!

5 About Product

5.1 Features

- **AI Tracking**

With the help of the AI computing power

- **NDI|HX2 (Optional)**

NDI|HX2 has the characteristics of low delay and plug and play, which is convenient for project implementation and deployment. It has good ecology and supports the simultaneous transmission of audio, video and control commands. It is a new generation of network video transmission mode.

- **4K UHD**

Use new 1/1.8-inch high-quality UHD CMOS sensor with a maximum of 8.42 million pixels can realize 4K (3840x2160) ultra-high-resolution high-quality images. And downward compatible with 1080P, 720P and other resolutions.

- **30x Optical Zoom**

It adopts 4K ultra long focal lens with high quality and 8 million ultra-high resolution, 30x optical zoom, and the maximum field angle is 59°.

- **HDMI 2.0**

Support HDMI 2.0 interface, which can directly output 4KP60 uncompressed digital video.

- **Low Light**

The application of 3D noise reduction algorithm greatly reduces image noise. Even under the condition of ultra-low illumination, it still keep the picture clean and clear, and the SNR of image is as high as 55dB.

- **Multiple Interfaces**

Support HDMI and 3G-SDI interface, effective transmission distance of 3G-SDI is up to 150 meters (1080P30). HDMI or 3G-SDI, USB, LAN can output three HD digital signals at the same time.

- **Remote Control**

Through the RS232 and RS485 serial ports, the camera can be controlled remotely.

- **Gravity Sensor**

It supports automatic image flipping function, which is convenient for engineering installation and use.

5.2 Specifications

Camera	
Signal System	HDMI: 4KP60, 4KP50, 4KP30, 4KP25, 4KP59.94, 4KP29.97, 1080P60, 1080P50, 1080P59.94, 1080P30, 1080P29.97, 1080I60, 1080I50, 1080I59.94, 720P60, 720P59.94 3G-SDI: 1080P60, 1080P50, 1080P30, 1080P29.97, 1080P59.94, 1080P25, 1080I60, 1080I50, 1080I59.94, 720P60, 720P59.94
Sensor	1/1.8 inch, CMOS, Effective pixels: 8.42M
Scanning Mode	Progressive
Lens	30x, f=7.1mm~210mm, F1.61~F5.19
Digital Zoom	16x
Minimum Illumination	0.5 Lux @ (F1.8, AGC ON)
Shutter	1/30s~1/10000s
White Balance	Auto, Indoor, Outdoor, One Push, Manual, VAR
Backlight Compensation	Support
Digital Noise Reduction	3D Digital Noise Reduction
SNR	≥55dB
Horizontal FOV	59.2°~2.5°
Vertical FOV	34.6°~1.4°
Pan Angle	±170°
Tilt Angle	-30°~+90°
Pan Speed	1.7°/s ~100°/s
Tilt Speed	1.7°/s ~69.9°/s
Image Flip	Support
Image Freeze	Support

PoE+	Support
Preset Position	255
Preset Accuracy	0.1°
USB Features (USB 3.0 Optional)	
Operate System	Windows 7/8/10, Mac OS X, Linux, Android
Color System/Compression	YUY2/H.264/H.265/MJPEG
USB3.0 Video Format (Optional)	<ul style="list-style-type: none"> YUY2: 1080P30 (max.) H.264 AVC: 4KP30 (max.) H.265 HEVC: 4KP30 (max.) MJPEG: 4KP30 (max.)
USB2.0 Video Format	<ul style="list-style-type: none"> YUY2: 1080P5 (max.) H.264 AVC: 4KP30 (max.) H.265 HEVC: 4KP30 (max.) MJPEG: 4KP30 (max.)
USB Audio	Support
USB Video Protocol	UVC 1.1~UVC 1.5
UVC PTZ	Support
Network Features	
Video Compression	H.264/H.265/MJPEG
Video Stream	First Stream, Second Stream
First Stream Resolution	3840x2160, 1920x1080, 1280x720, 1024x576, 720x480, 720x408, 640x480, 640x360
Second Stream Resolution	720x480, 720x408, 640x480, 640x360, 480x320, 320x240
Video Bit Rate	<ul style="list-style-type: none"> First Stream: 32kbps~51200kbps Second Stream: 32kbps~20480kbps
Bit Rate Control	CBR, VBR
Frame Rate	50Hz: 1fps~50fps 60Hz: 1fps~60fps

Audio Compression	AAC
Audio Bit Rate	96K, 128K
Protocols	NDI@HX2, TCP/IP, HTTP, RTSP, RTMP(S), ONVIF, DHCP, SRT, Multicast, etc.

Power Consumption	18W (max.)
Dimension	169mm x 188mm x 226mm
Net Weight	About 2.3Kg



Note Product specifications and parameters are subject to change without notice.

Interfaces

Audio Interface	1 x LINE IN: 3.5mm Audio Input Interface
	1 x LINE OUT: 3.5mm Audio Output Interface
Communication Interface	1 x RS485: 2pin phoenix port, Max Distance: 1200m, Protocol: VISCA/Pelco-D/Pelco-P
	1 x RS232 IN: 8pin Min DIN, Max Distance: 30m, Protocol: VISCA/Pelco-D/Pelco-P
	1 x RS232 OUT: 8pin Min DIN, Max Distance: 30m, Protocol: VISCA network use only
Network Interface	1 x LAN: 10M/100M/1000M Adaptive Ethernet Port
USB Interface	1 x USB2.0: Type-A
	1 x USB3.0: Type-B (Optional)
Video Interface	1 x 3G-SDI: BNC type, 800mVp-p, 75Ω. Along to SMPTE 424M standard
	1 x HDMI: Version 2.0
Power Interface	JEITA type (DC 12V)

General Specifications

Input Voltage	DC 12V/PoE+
Input Current	2A (max.)
Operating Temperature	0°C~40°C
Storage Temperature	-40°C~60°C

5.3 Interface and Switch

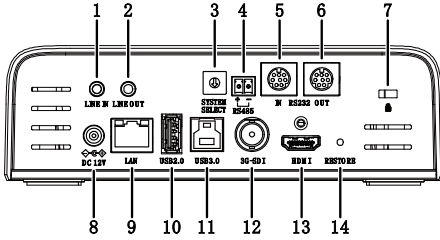

No.	Name
1	LINE IN Interface
2	LINE OUT Interface
3	SYSTEM SELECT Switch
4	RS485 Interface
5	RS232 IN Interface
6	RS232 OUT Interface
7	Security Slot
8	DC 12V Interface
9	LAN Interface
10	USB2.0 Interface
11	USB3.0 Interface
12	3G-SDI Interface
13	HDMI Interface
14	RESTORE Key

5.4 Dimension

Unit: mm

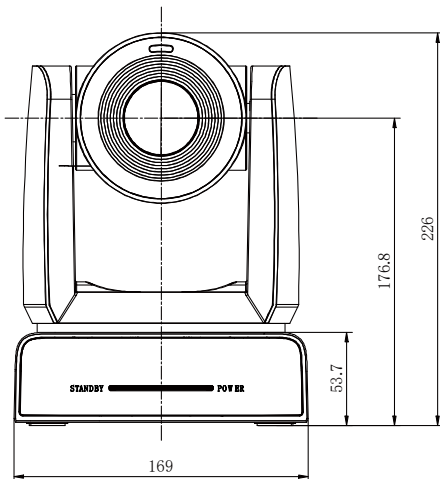

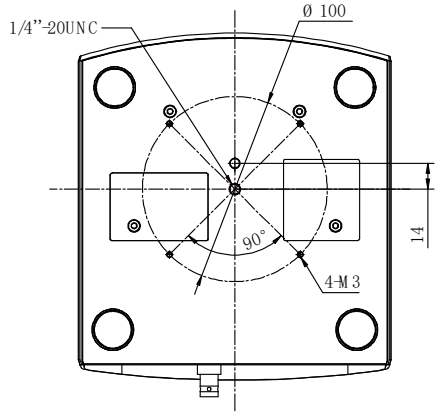
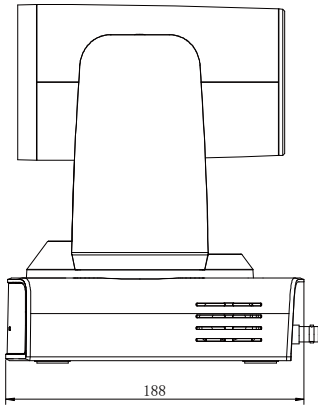

5.5 Installation

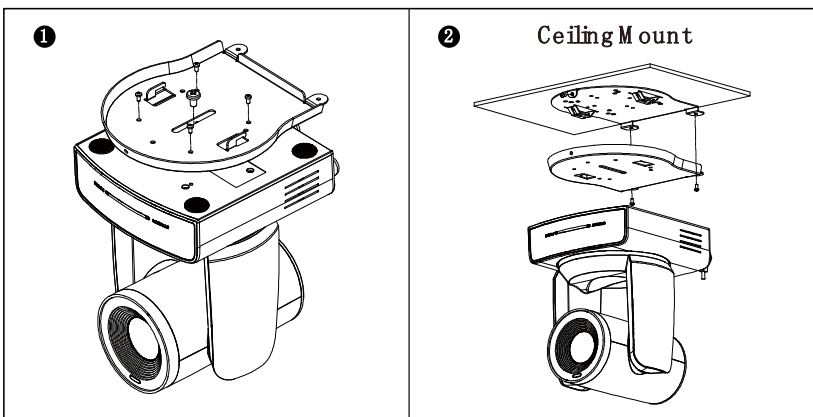
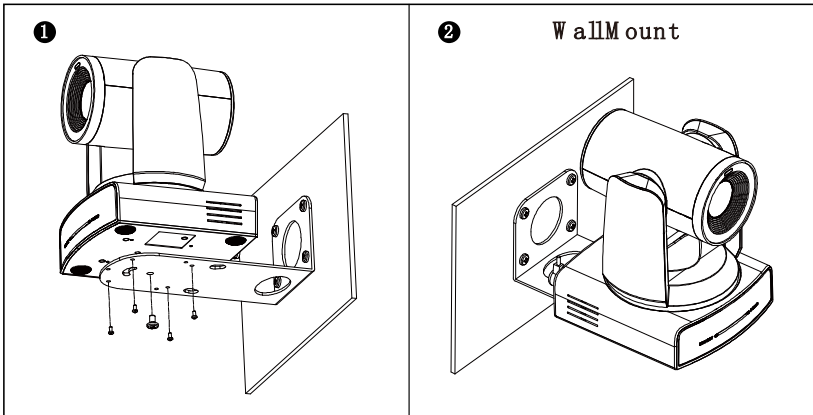

The above installation diagram is for reference only, please refer to actual

product for the installation accessories.

5.6 Remote Control

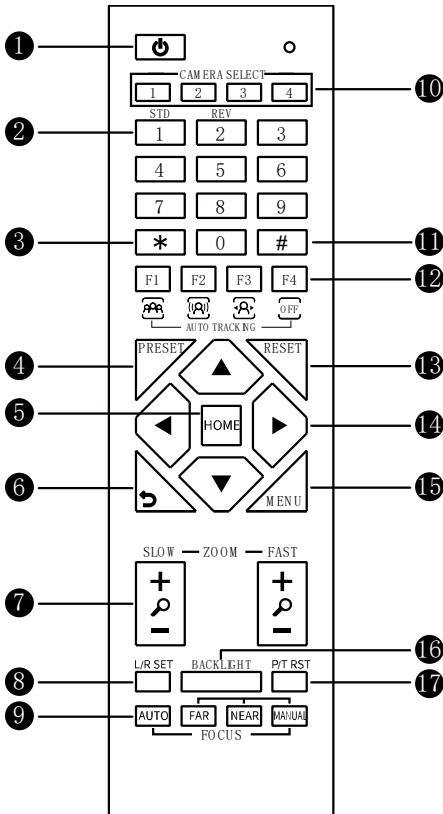

Key Description

1. ⏻ (Standby) Key

Press to enter standby mode

2. Number Keys

To set preset or call preset

3. * Key

Use with other keys

4. PRESET Key

Set preset: Successively press [PRESET] + Number key (0-9)

5. HOME Key

Confirm selection or press to turn PTZ back to the middle position

6. ↶ (Return) Key

Press to return to the previous menu

7. ZOOM Keys

- SLOW: Zoom In [+] or Zoom Out [-] slowly
- FAST: Zoom In [+] or Zoom Out [-] fast

8. L/R SET Key

- Standard: Simultaneously press [L/R SET] + [1]
- Reverse: Simultaneously press [L/R SET] + [2]

9. FOCUS Keys

Auto/Manual/Far-end/Near-end focus

10. CAMERA SELECT Keys

Press to select and control the camera

11. # Key

Use with other keys

12. Auto Tracking Keys

[F1]: Disable [F2]: Disable

[F3]: Enable AI Tracking

[F4]: Disable AI Tracking

13. RESET Key

Clear preset position: Successively press [RESET] + Number key (0-9)

14. PTZ Control Keys

PTZ moved according to the arrow indicates

15. MENU Key

Enter OSD menu or back to the previous menu

16. BACKLIGHT Key

Backlight ON/OFF: Press repeatedly to enable or disable the backlight compensation

- Effective only in auto exposure mode
- If there is a light behind the subject, the subject will become dark, press the backlight key to enable the backlight compensation. Press again to disable this function.

17. P/T RST (PTZ Reset) Key

Press to preset Pan/Tilt self-test

Shortcut Set

Successively press [#] + [*] + [F4]:

Enable or disable the Image Freeze

Successively press [*] + [#] + [1]:

OSD menu default English

Successively press [*] + [#] + [3]:

OSD menu default Chinese

Successively press [*] + [#] + [4]:

Display current IP address

Successively press [*] + [#] + [6]:

Quickly recover the default

Successively press [*] + [#] + [8]:

Check the camera version

Successively press [*] + [#] + [9]:

Quickly set up inversion

Successively press [*] + [#] +
[MANUAL]:

Restore to default IP address

6 GUI Settings

6.1 MENU

Press [MENU] key to display the main menu on the normal screen, using arrow key to move the cursor to the item to be set. Press the [HOME] key to enter the corresponding sub-menu.

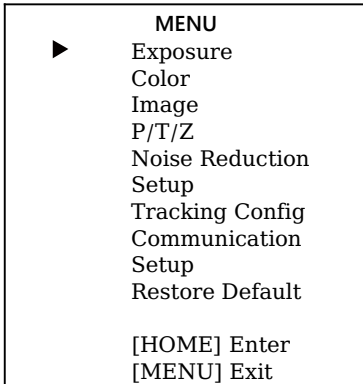

6.2 EXPOSURE

Move the main menu cursor to [Exposure], and press [HOME] key enter the exposure page, as shown in the following figure.

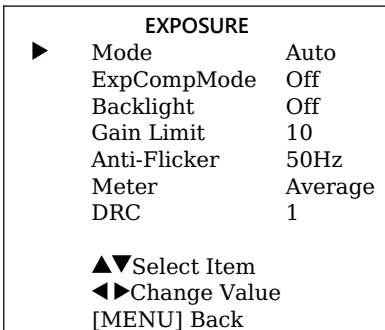

Mode: Auto, Manual, SAE, AAE, Bright.

ExpCompMode: On, Off (Effective only in Auto mode).

ExpComp: -7~7 (Effective only in ExpCompMode item to On).

Backlight: On, Off (Effective only in Auto mode).

Bright: 0~17 (Effective only in Bright mode).

Gain Limit: 0~15 (Effective only in Auto, SAE, AAE, Bright mode).

Anti-Flicker: Off, 50Hz, 60Hz (Effective only in Auto, AAE, Bright mode).

Meter: Average, Center, Smart, Top (Effective only in Auto, SAE, AAE, Bright mode).

Iris: F1.8, F2.0, F2.4, F2.8, F3.4, F4.0, F4.8, F5.6, F6.8, F8.0, F9.6, F11.0, Close (Effective only in Manual, AAE mode).

Shutter: 1/30, 1/60, 1/90, 1/100, 1/125, 1/180, 1/250, 1/350, 1/500, 1/725, 1/1000, 1/1500, 1/2000, 1/3000, 1/4000, 1/6000, 1/10000 (Effective only in Manual, SAE mode).

Gain: 0~7 (Effective only in Manual mode).

DRC: 0~8.

6.3 COLOR

Move the main menu cursor to [Color], and press [HOME] key enter the color page, as shown in the following figure.

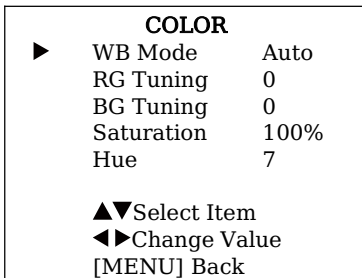

WB Mode: Auto, Indoor, Outdoor, One Push, Manual, VAR.

RG: 0~255 (Effective only in Manual mode).

BG: 0~255 (Effective only in Manual mode).

RG Tuning: -10~+10 (Effective only in Auto, One Push, VAR mode).

BG Tuning: -10~+10 (Effective only in Auto, One Push, VAR mode).

Saturation: 60%~200%.

Hue: 0~14.

6.4 IMAGE

Move the main menu cursor to [Image], and press [HOME] key enter the image page, as shown in the following figure.

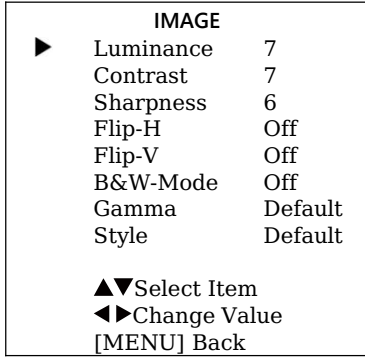

Luminance: 0~14.

Contrast: 0~14.

Sharpness: 0~11.

Flip-H: On, Off.

Flip-V: On, Off.

B&W-Mode: On, Off.

Gamma: Default, 0.45, 0.48, 0.5, 0.56, PC.

Style: Default, Norm, Bright, PC.

6.5 P/T/Z

Move the main menu cursor to [P/T/Z], and press [HOME] key enter the P/T/Z page, as shown in the following figure.

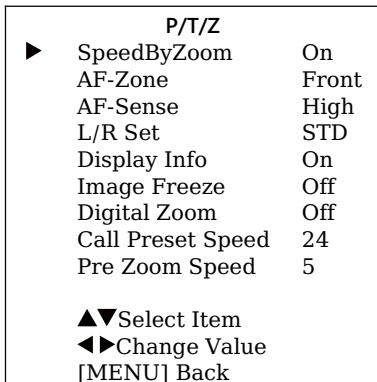

SpeedByZoom: On, Off.

AF-Zone: Front, Top, Center, Bottom.

AF-Sense: High, Low, Normal.

L/R Set: STD, REV.

Display Info: On, Off.

Image Freeze: On, Off.

Digital Zoom: Off, 2x, 4x, 8x, 16x.

Call Preset Speed: 1~24.

Pre Zoom Speed: 0~7.

6.6 NOISE REDUCTION

Move the main menu cursor to [Noise Reduction], and press [HOME] key

enter the noise reduction page, as shown in the following figure.

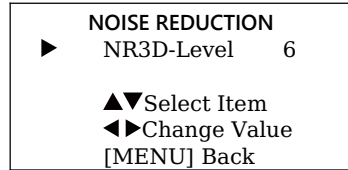

NR3D Level: Off, 1~9.

6.7 SETUP

Move the main menu cursor to [Setup], and press [HOME] key enter the setup page, as shown in the following figure.

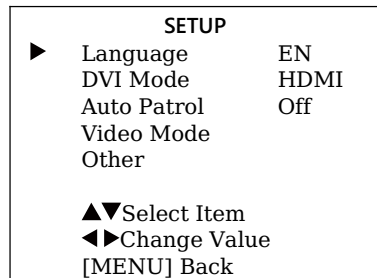

Language: EN, Chinese, Russian.

DVI Mode: HDMI, DVI.

Auto Patrol: On, Off.

Residence Time: 1~60 (Effective only in Auto Patrol item to On).

Call Preset Speed: 1~24 (Effective only in Auto Patrol item to On).

Video Mode: Press the [HOME] key to confirm enter the "Video Mode" page and set SDI-3G Mode, Video Output.

SDI-3G Mode: LEVEL-A, LEVEL-B.

Video Output: HDMI, SDI.

Other: Press the [HOME] key to confirm enter the "Other" page and set Auto Inversion, Tally Mode, and Preset Parameters.

Auto Inversion: On, Off.

Tally Mode: On, Off.

Preset Parameters: On, Off.

COMMUNICATION SETUP
[MENU] Back

Protocol: Auto, VISCA, PELCO-D, PELCO-P.

6.8 TRACKING CONFIG

Move the main menu cursor to [Tracking Config], and press [HOME] key enter the tracking config page, as shown in the following figure.

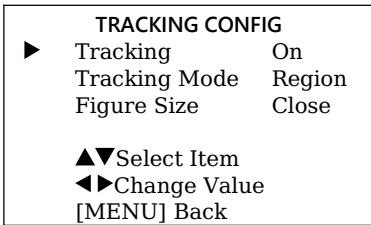

Tracking: On, Off.

Tracking Mode: Region, Presenter.

Figure Size: Full, Upper, Close, Custom.

6.9 COMMUNICATION SETUP

Move the main menu cursor to [Communication Setup], and press [HOME] key enter the communication setup page, as shown in the following figure.

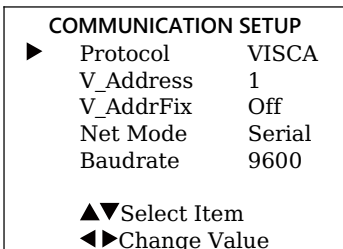

V_Address: 1~7 (Effective only in Auto, VISCA protocol).

V_AddrFix: On, Off (When set to On, useless in 88 30 01 FF Command).

P_D_Address: 0~254 (Effective only in Auto, PELCO-D protocol).

P_P_Address: 0~31 (Effective only in Auto, PELCO-P protocol).

Net Mode: Serial, Paral (Effective only in Auto, VISCA protocol).

Baudrate: 2400, 4800, 9600, 38400.



6.10 RESTORE DEFAULT

Move the main menu cursor to [Restore Default], press [HOME] key enter restore default page, as shown in the following figure.

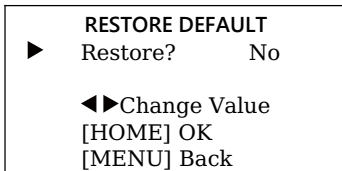

Restore: Yes, No.



GUI menu and device information are subject to change without notice.

7 WEB Settings

7.1 Access Camera

Access <http://192.168.100.88> to pop up the login window, then input username (default: admin) and password (default: admin). After login, it will show as below:

7.2 Control Camera

All pages include two menu bars:

Real Time Monitoring: Video image displaying with function buttons.

Parameter Setup: Parameter configuring.

A. Video Viewing Window

The video viewing window is same as video resolution, the bigger the resolution, the bigger the playing area. Double click the viewing window to show full screen, double click again, to return to initialized size.

Status bar in viewing window shown as below:



 Full screen switch button.

B. PTZ Setup

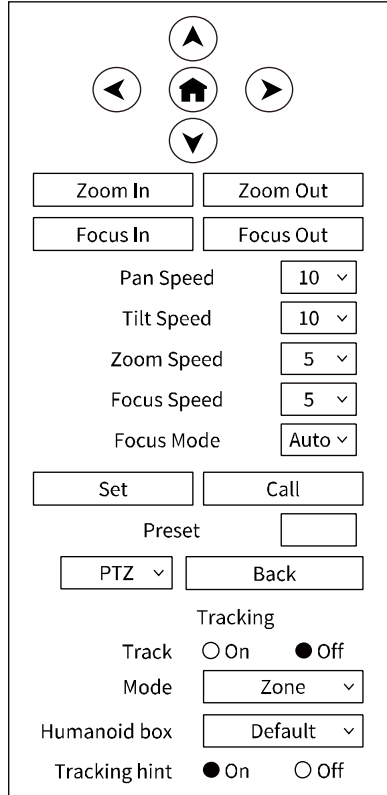

1) Pan and Tilt Control

The direction arrows and HOME button allow you to manually drive the camera to desired position.

2) Zoom

Zoom In and Zoom Out buttons allow for wide or narrow view of the space.

3) Focus

Focus In and Focus Out button allow for fine manual focus adjustment if the camera has any auto focusing problems on difficult object.

4) PTZ Speeds

Pan speed rate can be set to 1~24, Tilt speed rate can be set to 1~20. Zoom and Focus speed rate can be set to 1~7.

5) Focus Mode

Focus Mode can be selected Auto/Manual. When you select "Manual", Focus In and Focus Out will take effect.

6) PTZ Presets

When the PTZ turns to the position that you would like to return to later, you can set presets for quick recall. Type a number (0~254) into the preset box and click "Set" button to save.

When the PTZ turn to other position, input the preset number and click "Call" button to turn the PTZ back to the preset position.

7) PTZ/OSD

Move the cursor to dropdown menu, select and click "OSD" to open the on-screen menu and do menu settings on the interface.

8) Tracking

Turn On/Off the Track function and Tracking hint. Set Mode (Zone, Presenter) and Humanoid box.

C. Language Selection

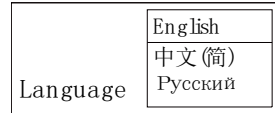

Click either "Chinese", "English" or "Russian" to change the language of the webpage.

7.3 Video Settings

Video Settings

HDMI/SDI Output

Video Format

Encode Level

First Stream

Encode Protocol

Resolution

Bit Rate

Frame Rate fps

IKey Frame Interval

BitRate Control

Second Stream

Encode Protocol

Resolution

Bit Rate

Frame Rate fps

IKey Frame Interval

BitRate Control

1) HDMI/SDI Output

Support HDMI and SDI Output.

2) Video Format

Support 50Hz, 60Hz and Dial Priority.

3) Encode Level

Support mainprofile and highprofile two levels.

4) Encode Protocol

Support H264, H265 and MJPEG protocols.

5) Resolution

First stream support 3840x2160, 1920x1080, 1280x720, 1024x576, 720x480, 720x408, 640x480, 640x360. Second stream support 720x480, 720x408, 640x480, 640x360, 480x320, 320x240; The bigger resolution is, the clearer the image will be, more network bandwidth will be taken.

6) Bit Rate

The user can specify the bit rate.

Generally speaking, the larger of the bit rate, the clearer of the image. However, the configuration of the bit rate needs to be combined with the network bandwidth. When the network bandwidth is narrow and the bit rate is configured larger, the video stream cannot be transmitted normally, and the visual effect is worse.

7) Frame Rate

User can specify the size of the frame rate, generally, the frame rate greater, the image more smooth; Frame rate is smaller, the more sense of beating.

8) I Key Frame Interval

Set interval between 2 I frame, the bigger interval is the response will be lower from view window.

9) Bit Rate Control

Code stream control way:

CBR (Constant Bit Rate): Video coder will be coding according to preset speed.

VBR (Variable Bit Rate): Video coder will adjust the speed based on preset speed to gain the best image quality.

7.4 Tracking Settings

7.4.1 Presenter



1) Auto Zoom/Auto Tilt

When Auto Zoom or Tilt is off, camera stops

zooming in/out or tilting automatically.

Determine the zoom size and tilt position based on the tracking start position you choose. When auto zoom is off, camera stops zooming In/Out automatically. When auto tilt is off, camera only move horizontally.

2) Target Retention Time

Set Target Retention Time, the time to return to the starting point after losing the target.

3) Figure Size

Figure Size: Full, Upper, Close, Custom.

4) Tracking Start Position

Tracking Start Position: Current Location, Preset 1.

5) Character Position

Character Position: Left, Middle, Right.

have overlap.

2) Tracking Start Area

Tracking Start Area: Zone A, Zone B, Zone C, Zone D.

7.4.2 Zone



1) Zone Setting

Zone Setting: Zone A, Zone B, Zone C, Zone D. Set area tracking must be set "from left to right", and each area must

7.5 Image Settings

7.5.1 Exposure

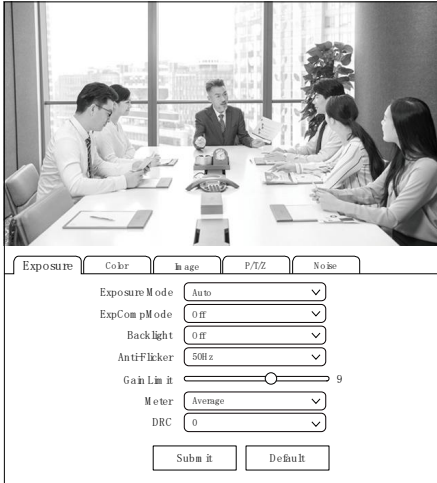

1) Exposure Mode

Exposure Mode: Auto, Manual, SAE, AAE, Bright.

2) ExpCompMode

ExpCompMode: On, Off.

3) Backlight

Backlight: On, Off.

4) Anti-Flicker

Anti-Flicker: Off, 50Hz, 60Hz.

5) Gain Limit

Gain Limit: 0~15.

6) Meter

Meter: Average, Center, Smart, Top.

7) DRC

DRC: 0~8.

7.5.2 Color

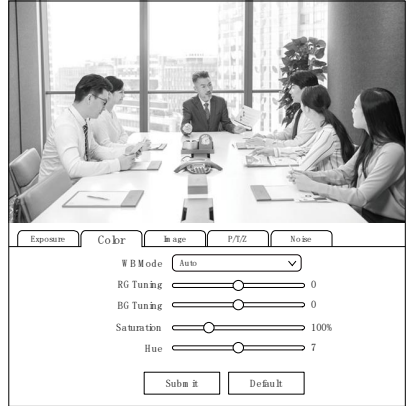

1) WB Mode

WB Mode: Auto, Indoor, Outdoor, Manual,
One Push, VAR.

2) RG Tuning

RG Tuning: -10~10.

3) BG Tuning

BG Tuning: -10~10.

4) Saturation

Saturation: 60%~200%.

5) Hue

Hue: 0~14.

7.5.3 Image

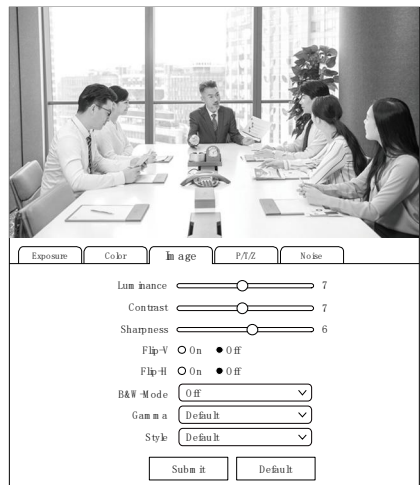

1) Luminance

Luminance: 0~14.

2) Contrast

Contrast: 0~14.

3) Sharpness

Sharpness: 0~11.

4) Flip-V

Turn On/Off the Flip-V function.

5) Flip-H

Turn On/Off the Flip-H function.

6) B&W-Mode

B&W-Mode: On, Off.

7) Gamma

Gamma: Default, 0.45, 0.48, 0.5, 0.56, PC.

8) Style

Style: Default, Norm, Bright, PC.

7.5.4 PTZ



1) AF-Zone

AF-Zone: Top, Center, Bottom, Front.

2) AF-Sense

AF-Sense: High, Normal, Low.

3) Image Freeze

Image Freeze: On, Off.

7.5.5 Noise

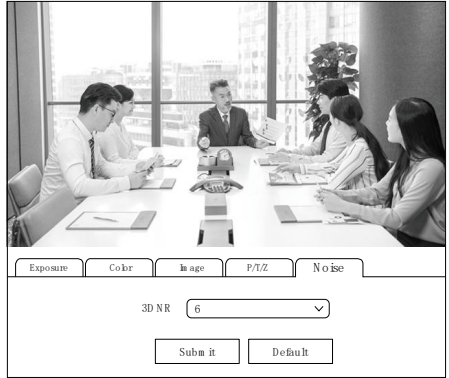

3D NR: Off, 1~9.

7.6 Audio Settings

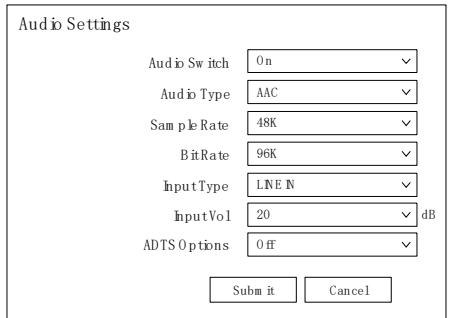

1) Audio Switch

Turn On/Off the audio switch.

2) Audio Type

Audio Type: AAC.

3) Sample Rate

Sample Rate: 44.1K, 48K.

4) Bit Rate

Bit Rate: 96K, 128K.

5) Input Type

Input Type: LINE IN, MIC.

6) Input Vol

Select the volume value to control the channel volume.

7) ADTS Options

Options: On/Off.

7.7 System Settings

7.7.1 Initialize

Reboot	<input type="button" value="Reboot"/>
Factory Default	<input type="button" value="Factory Default"/>

1) Reboot

Click “Reboot” to restart system.

2) Factory Default

Click the “Factory Default”, and the “Please press OK to reset the camera.” dialog box pops up. Select “OK” to restore the factory default.

7.7.2 User

User Name	<input type="text" value="admin"/>
Password	<input type="password" value="....."/> <input type="checkbox"/>
Guest	<input type="text" value="guest"/>
Password	<input type="password" value="....."/> <input type="checkbox"/>
<input type="button" value="Submit"/> <input type="button" value="Cancel"/>	

Username and Password

Modify the password of username and guest (only use letters and numbers).

7.7.3 U Disk Record

Record Settings	
File Format	<input type="text" value="MP4"/>
Packed Time (min)	<input type="text" value="15"/>
<input type="button" value="Save"/>	
USB Flash Disk Information	
Capacity (M)	<input type="text" value="3846"/>
Free Space (M)	<input type="text" value="300"/>
<input type="button" value="Mount"/> <input type="button" value="Unmount"/> <input type="button" value="Format"/>	

1) Record Settings

Set up the File Format and Packed Time.

2) USB Flash Disk Information

View the Capacity and Free Space of the USB Flash Disk.

7.7.4 Online Upgrade

<div style="border: 1px dashed gray; padding: 10px; width: fit-content; margin: 0 auto;"> Please Add Or Drag Files To This Area. Or Click Upload </div>
Only Upload *.img Files <input type="button" value="Update"/>

The device supports online upgrade. If you need to upgrade the camera program, please refer to the upgrade interface instructions (as shown in the above figure), select the upgrade file package, and click the “Update” to upgrade the program.

7.8 Network Settings

7.8.1 Lan

IP Configuration Type	<input type="text" value="Fixed IP Address"/>
IP Address	<input type="text" value="192.168.100.88"/>
Subnet Mask	<input type="text" value="255.255.255.0"/>
Gateway	<input type="text" value="192.168.100.1"/>
DNS Address	<input type="text" value="8.8.8.8"/>
MAC Address	<input type="text" value="D4E08E1E2020"/>
DHCP timeout	<input type="text" value="30 sec"/>
Static fallback address	<input type="text" value="192.168.100.88"/>
Static fallback Subnet Mask	<input type="text" value="255.255.255.0"/>
<input type="button" value="Submit"/> <input type="button" value="Cancel"/>	

The default camera IP: 192.168.100.88.
The MAC address cannot be modified.

7.8.2 Port

Click “Submit” and restart to take effect.

HTTP Port	<input type="text" value="80"/>
RTSP Port	<input type="text" value="554"/>
TCP Port	<input type="text" value="5678"/>
UDP Port	<input type="text" value="1259"/>
Sony Visca	<input type="text" value="52381"/>
<input type="button" value="Submit"/> <input type="button" value="Cancel"/>	

Set the HTTP Port, RTSP Port, TCP Port, UDP Port and Sony Visca of the camera.

A. HTTP Port

The IP address identifies a network device and multiple network programs can run on the device, each network program uses the network port for data transmission. The port setting on this page is to set up which port the WEB SERVER program uses to transmit. During port mapping, it needs to be consistent with port number (default is 80).

B. RTSP Port

Set up the RTSP Port, default is 554.

C. TCP Port

Set up the TCP Port, default is 5678.

D. UDP Port

Set up the UDP Port, default is 1259.

E. Sony Visca

Set up the Sony Visca, default is 52381.

7.8.3 RTMP(S)

First Stream	<input type="radio"/> On <input checked="" type="radio"/> Off <input type="checkbox"/> Video <input type="checkbox"/> Audio
MRL	<input type="text" value="rtmp://192.168.100.138/live/stream 0"/>
Second Stream	<input type="radio"/> On <input checked="" type="radio"/> Off <input type="checkbox"/> Video <input type="checkbox"/> Audio
MRL	<input type="text" value="rtmp://192.168.100.138/live/stream 1"/>
<input type="button" value="Submit"/> <input type="button" value="Cancel"/>	

Set the MRL of RTMP(S) and select “On”, “Off”, “Video” and “Audio” functions to enable or disable video and audio in the two streams.

7.8.4 SRT Settings

SRT	<input checked="" type="radio"/> On <input type="radio"/> Off
SRT Mode	Listener
SRT Server	192.168.100.1
SRT Port	4578
SRT Encryption	None
SRT Password	1234564913131
SRT Bandwidth Overhead	25
SRT Variable Latency	500
SRT Stream ID	#!:a=admin
<input type="button" value="Submit"/> <input type="button" value="Cancel"/>	

Turn On/Off SRT and set up the SRT Mode, SRT Server, SRT Port, SRT Encryption, SRT Password, SRT Bandwidth Overhead, SRT Variable Latency and SRT StreamID.

7.8.5 RTSP

RTSP Auth	<input type="radio"/> On <input checked="" type="radio"/> Off
<input type="button" value="Submit"/> <input type="button" value="Cancel"/>	

Turn On/Off the RTSP Auth.

7.8.6 ONVIF

ONVIF	<input type="radio"/> On <input checked="" type="radio"/> Off
ONVIF Auth	<input type="radio"/> On <input checked="" type="radio"/> Off
<input type="button" value="Submit"/> <input type="button" value="Cancel"/>	

Turn On/Off the ONVIF and ONVIF Auth.

7.8.7 Multicast

Multicast	<input type="radio"/> On <input checked="" type="radio"/> Off
Address	224.1.2.3
Port	6688
<input type="button" value="Submit"/> <input type="button" value="Cancel"/>	

Turn On/Off Multicast, set up Multicast

Address (default is 224.1.2.3) and Port (default is 6688; 6688 is the multicast port of the first stream and 6690 is the multicast port of the second stream).

7.8.8 Freed

Freed Data Output(beta)	<input type="radio"/> On <input checked="" type="radio"/> Off
Destination IP	192.168.100.99
ControlPort	19147
Data Port	19148
<input type="button" value="Submit"/> <input type="button" value="Cancel"/>	

Turn On/Off Freed Data Output, set up the Destination IP, Control Port and Data Port.

7.8.9 NTP

NTP Time Sync	<input type="radio"/> On <input checked="" type="radio"/> Off
Time Zone	(GMT+08:00) Beijing, China
Server Address	cn.ntp.org.cn
Time Interval(min)	1440
<input type="button" value="Submit"/> <input type="button" value="Cancel"/>	

Turn On/Off NTP Time Sync, set up the Time Zone, Server Address (default is cn.ntp.org.cn) and Time Interval (default is 1440 min).

7.9 Overlay

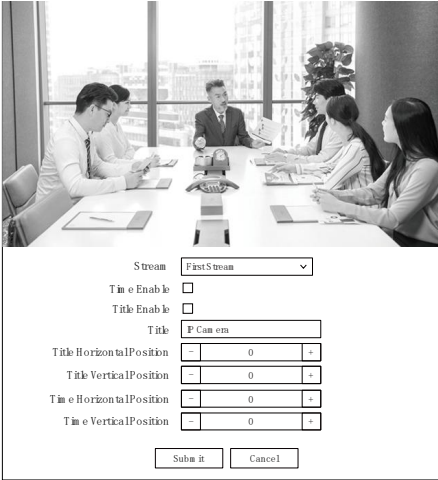

are subject to change without notice.

8 AI Tracking

8.1 Web Control

- **Speaker (Presenter)/Human Tracking**
By modifying web interface parameters, different close-up ratios can be obtained, and tracking can be set on/off, so as to display areas and character positions. If necessary, you can also choose whether to display tracking related prompt information.

1) Stream

Stream: First Stream, Second Stream.

2) Time Enable

Enable or disable the Time.

3) Title Enable

Enable or disable the Title.

4) Title

Set up the Title of the display screen.

5) Title Horizontal Position

Set up the Title Horizontal Position.

6) Title Vertical Position

Set up the Title Vertical Position.

7) Time Horizontal Position

Set up the Time Horizontal Position.

8) Time Vertical Position

Set up the Time Vertical Position.

7.10 Device Information

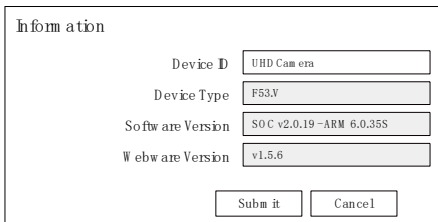

WEB interface and device information

The operation steps are as follows:

Step 1 Enter the current IP address, account, and password of the camera through the browser (see WEB Settings) to log in to the camera web interface.

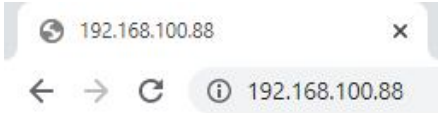

Step 2 Enter the "Tracking" option, select speaker mode "Presenter", and set the tracking parameters in the "Track Off" state.

Tracking Mode: Speaker
(Presenter)/Area (Zone)

The default is Presenter Mode.

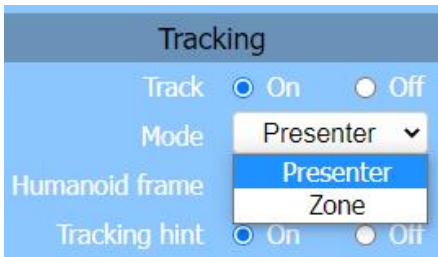
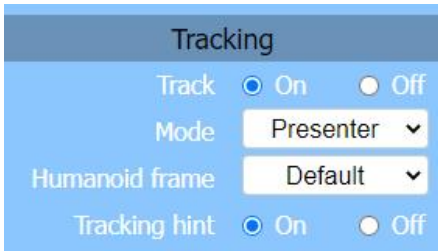

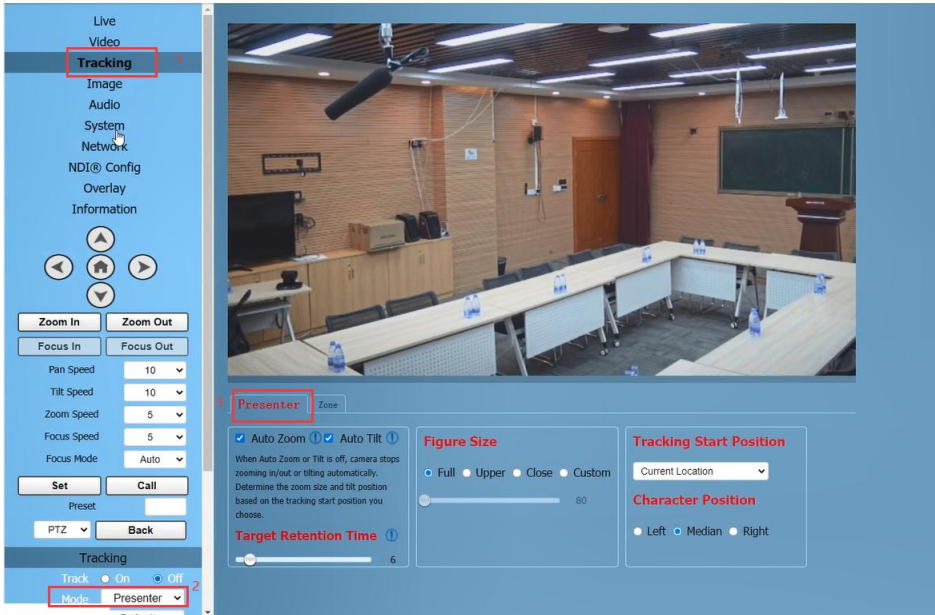

Step 3 We can consider how long the Target Retention Time will take, with a default of 6 seconds and a maximum of 10 seconds.

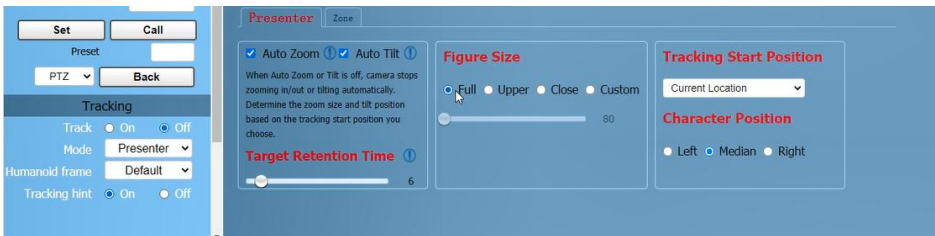

Auto Zoom: Usually remains the default. When “Auto Zoom” is turned off, the camera lens can still move, but can only maintain the current magnification and cannot zoom.
Auto Tilt: Usually remains default. When “Auto Tilt” is turned off, the camera lens can only move horizontally.

Target Retention Time: can remain default. It is an important function to set how long it takes for the camera lens to return to the Home position or starting position after the tracking target is lost. The modification here takes effect immediately.

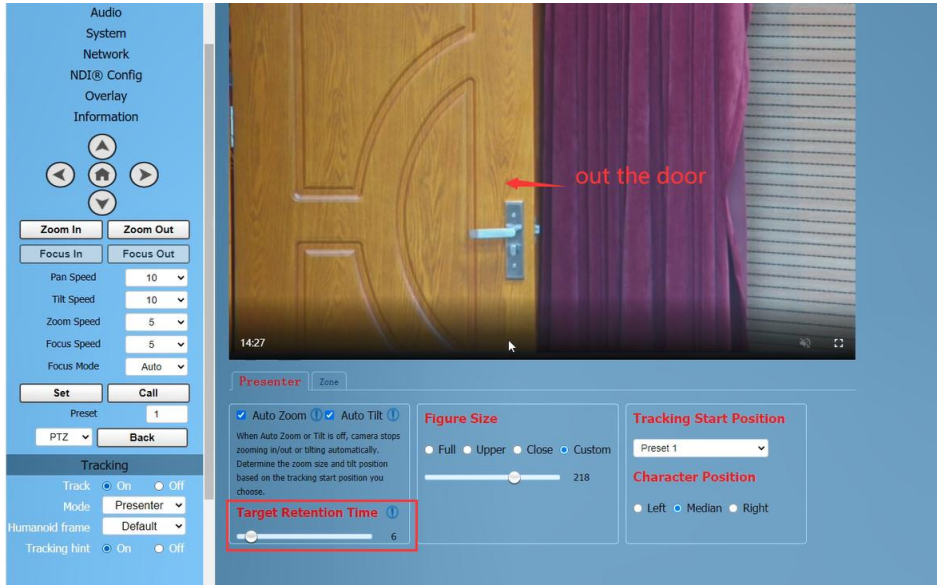
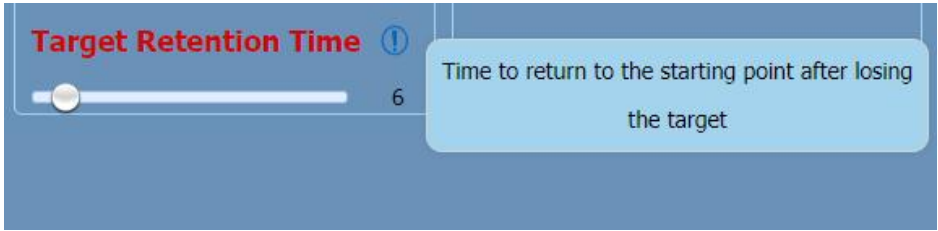

Step 4 Select the desired close-up effect.

● **Figure Size**

By selecting different modes, users can customize the proportion of characters in the close-up screen, which is a very important feature. The modification here takes effect immediately.

Full: The close-up image includes tracking the entire body of the target, as shown in the following figure.

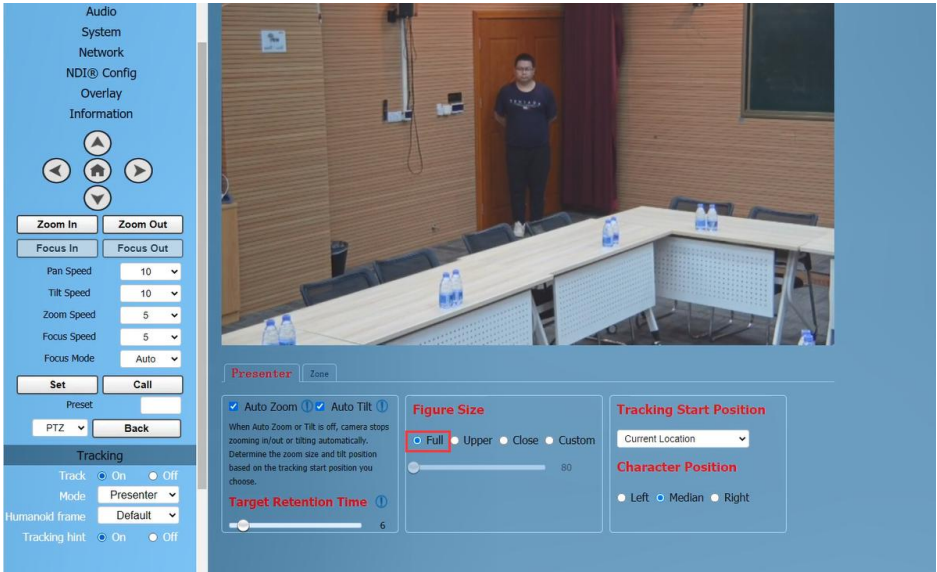

Upper: The close-up image includes tracking the target above the knee, as shown in the following figure.



Close: The close-up image includes tracking the target above the waist, as shown in the following figure.

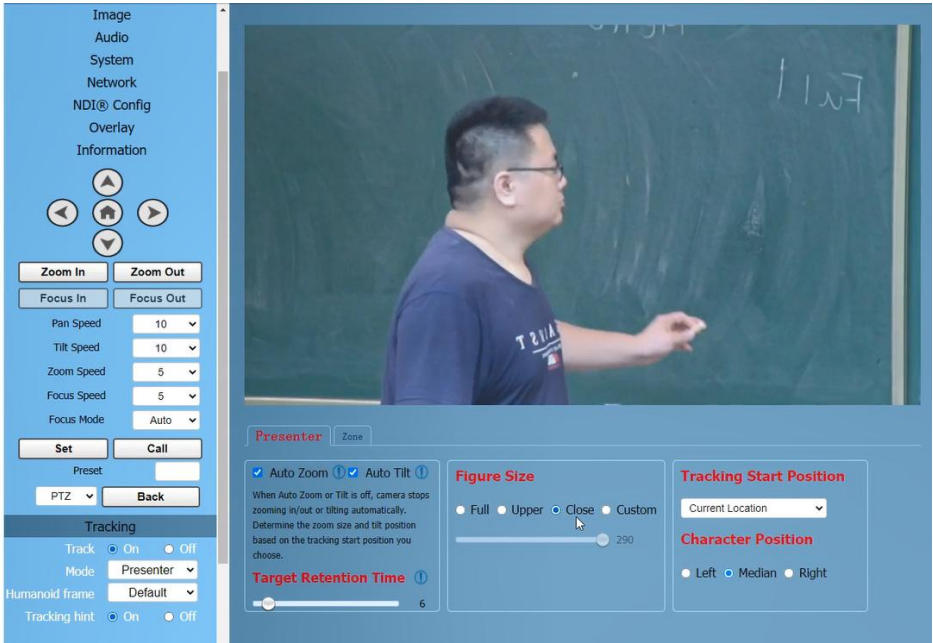

Custom: Adjust the tracking target proportion size.

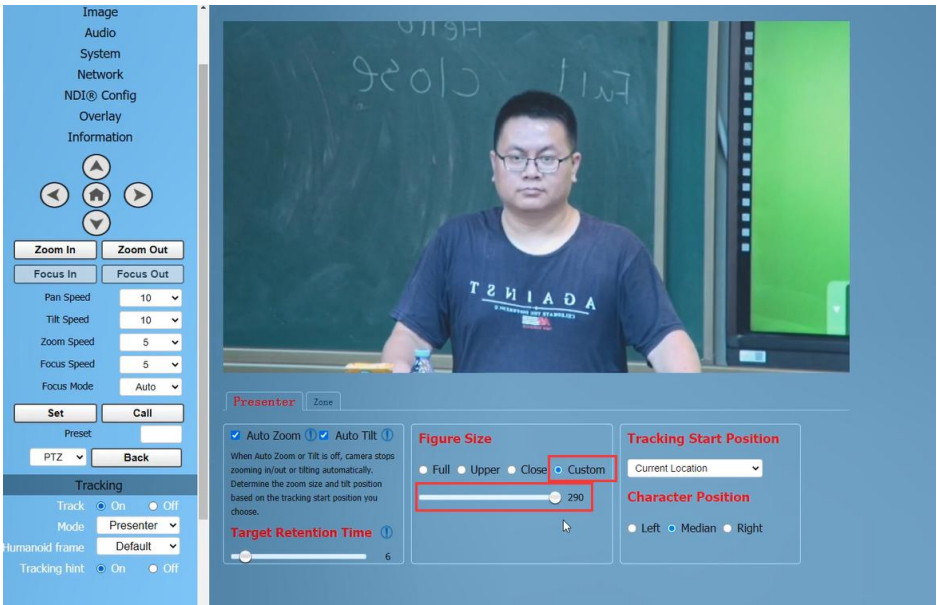



If the proportion set is large, the proportion of the tracking target in the camera screen will also increase. When the tracking target moves rapidly, the camera may not keep up.

● Tracking Start Position

The user can choose the position of the camera lens when starting and stopping tracking.

Two Mode: Current Location/Preset 1

If you choose “Current Location”, the camera position when tracking is turned on is the current position; Similarly, the camera position when stopping tracking will also stop at the current position.

If you choose “Preset 1”, you need to set an additional preset position for the camera. When tracking is turned on, the camera will first move to Preset 1. If someone enters the video screen at this time, the camera will automatically track. When the tracking target is lost (exceeding the timeout), the camera will automatically move to Preset 1.

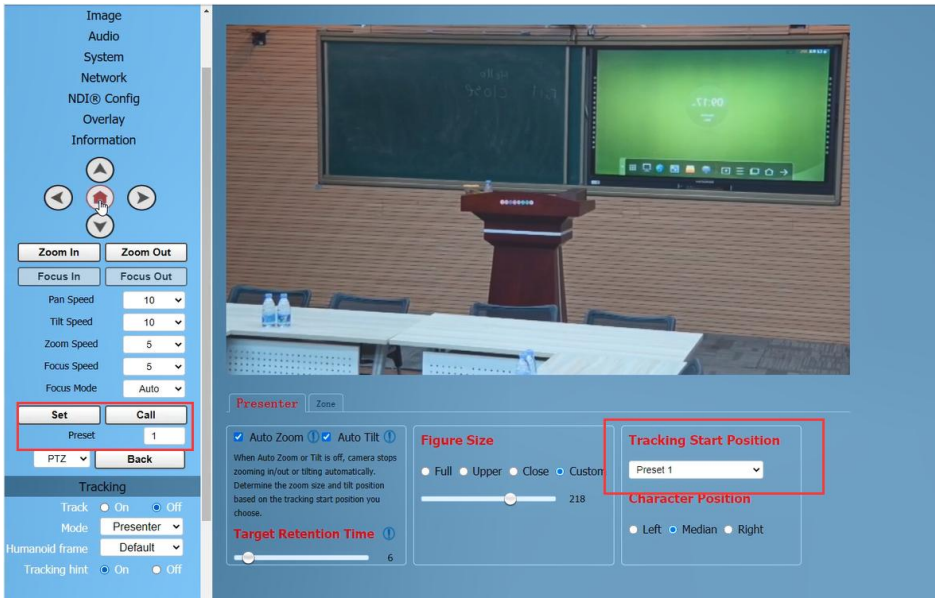

● Character Position

Character Position: defaults to median. Left or right can be selected by oneself, and this function is mostly used for live streaming scenes.

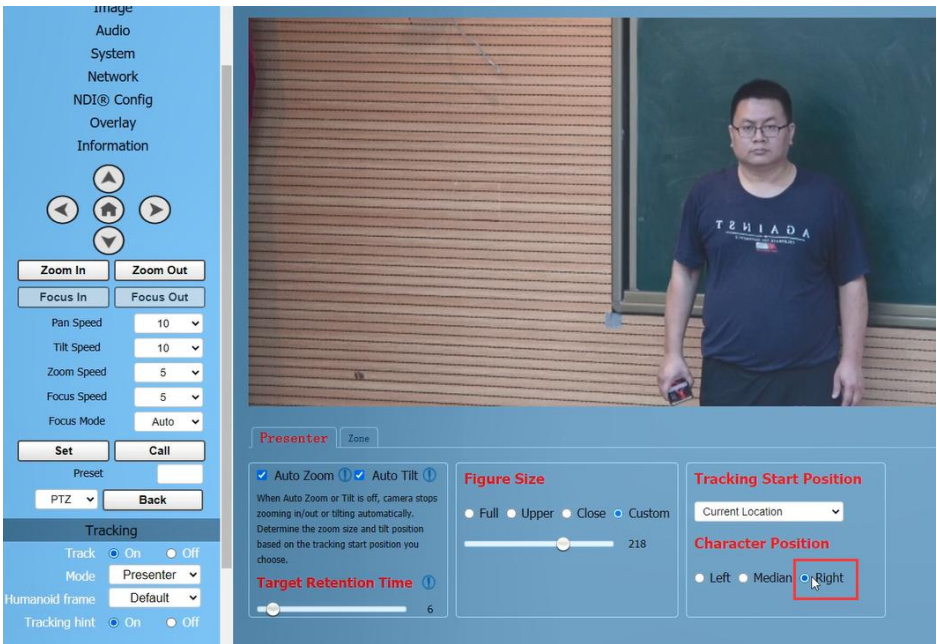
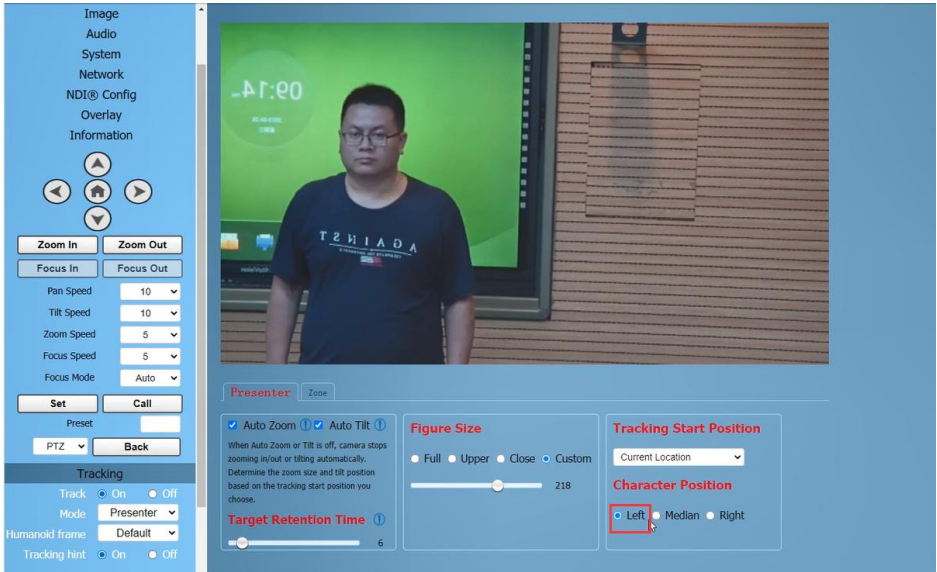

Step 5 According to the requirements of the application scenario, you can choose whether to require

“Humanoid frame” and “Tracking hint”, with default modes.

Used in live streaming scenarios, it is often not opened for temporary adjustments

during live streaming.

Humanoid frame: Default/Off/Debug

Default: After turning on tracking, if there are multiple people in front of the camera and pressing the direction key to select the tracking target, this box will automatically appear. After pressing the HOME key to confirm tracking, this box will disappear and the camera will start tracking.

Off: When selecting a tracking target, the humanoid box is not displayed at all. This feature is suitable for live streaming scenarios.

Debug: Turn on tracking, and the humanoid box will always appear on the tracking target. This feature is only applicable for debugging or demonstration.

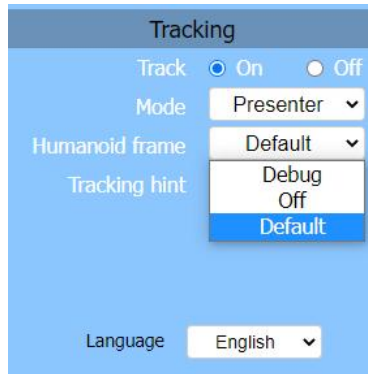

Tracking hint: On/Off

On: There will be a prompt in the upper left corner of the video during switch tracking.

Off: There is no prompt in the upper left corner of the video during switch tracking.

This function is also applicable to live streaming scenarios.



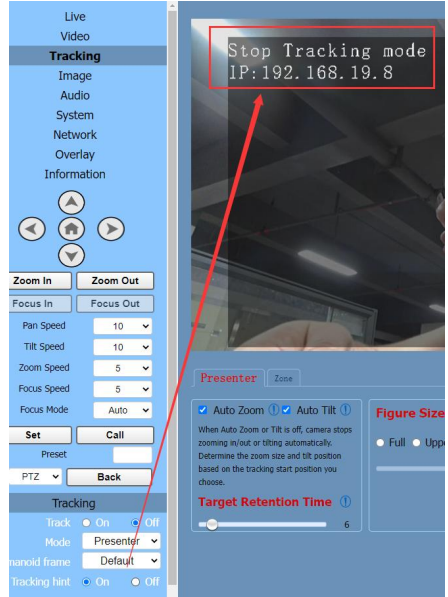
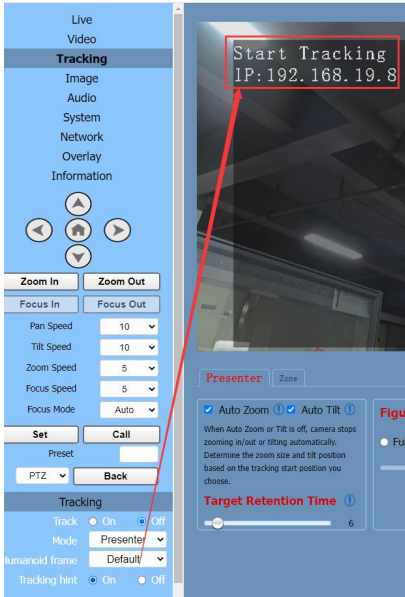

Step 6 Turn on tracking, press the arrow keys to select the tracking target, and then press Home to confirm.

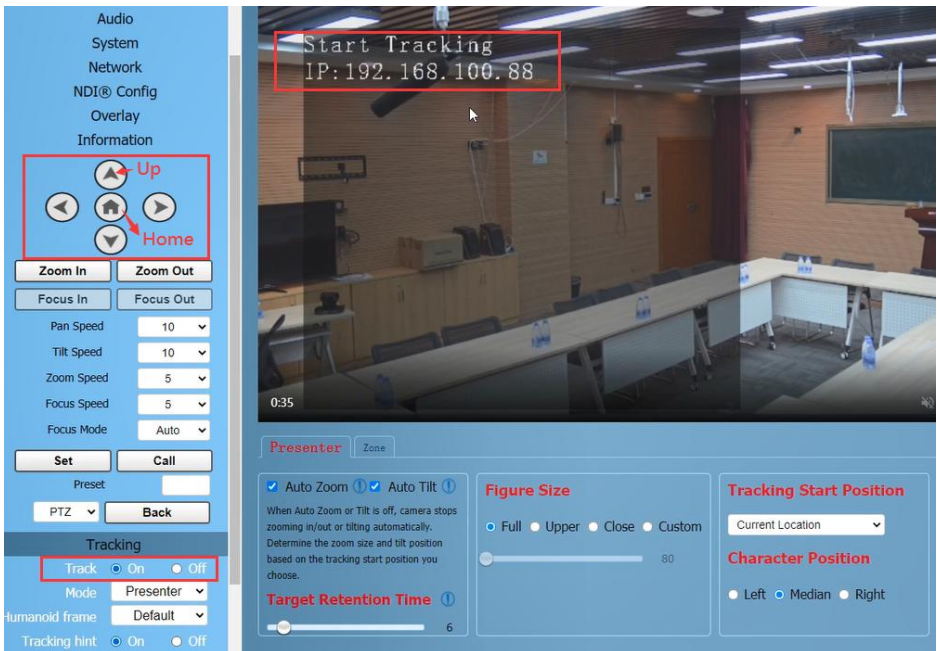

● **Area Tracking (Zone)**

Function: Divide the frequently active areas of the tracking target into several areas (A, B, C, D) as needed, and set corresponding preset positions and save them. When the tracking target enters this area, the camera will automatically call the preset position corresponding to the area to achieve tracking.

Operation Method:

Step 1 Enter the current IP address, account, and password of the camera through the browser

(see WEB Settings), you can log in to the camera web interface.

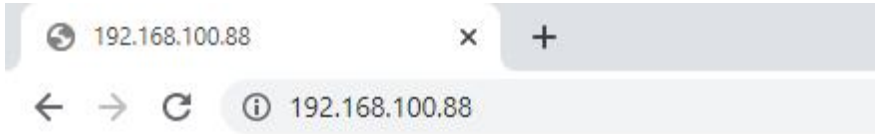

Step 2 Enter the “Tracking” page and select “Zone”. In the track off state, set the tracking parameters.

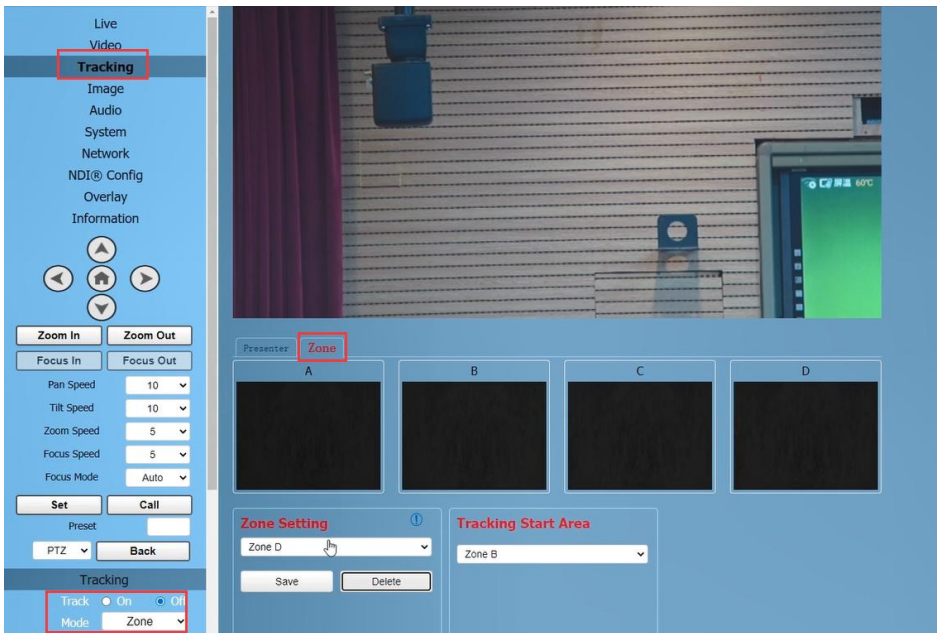

Step 3 Use the web interface's directional keys and Zoom In/Out to adjust the lens position,

and set multiple preset positions such as Zone A successively, and click “Save”.

The number of preset positions to be used in actual application scenarios can be considered by users themselves, but currently the maximum is 4. If the settings are incorrect, you can delete or reset them.

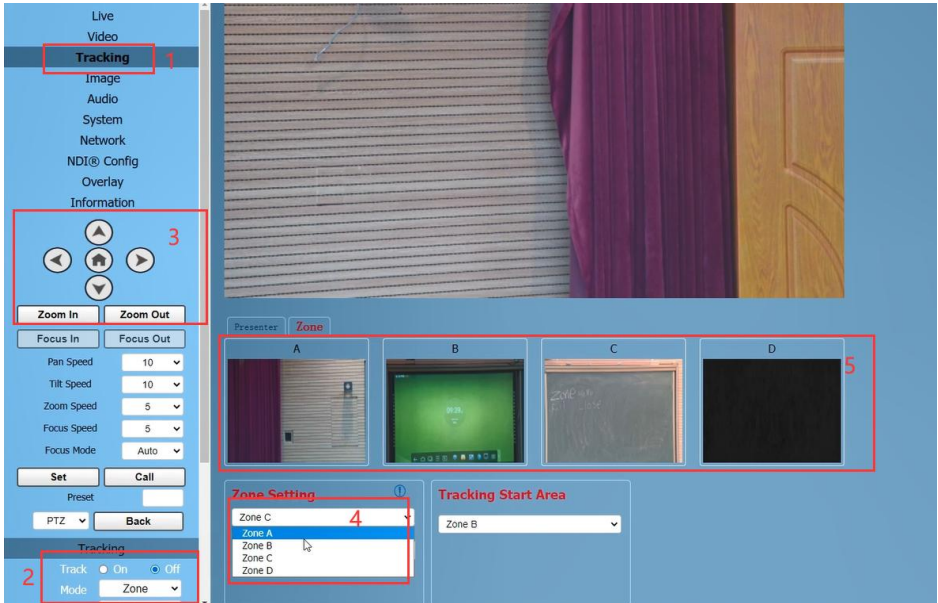

● **Tracking Start Area**

Tracking Start Area: You can select any Zone position as the tracking start or end position. When tracking is turned on, the camera will first move to this Zone position. If someone enters the video screen at this time, the camera will automatically track. When the tracking target is lost, the camera will automatically move to this Zone position.

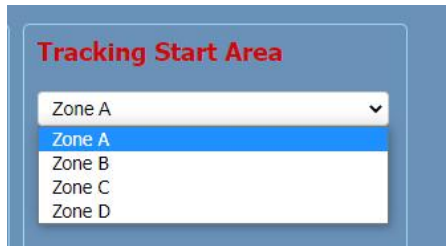
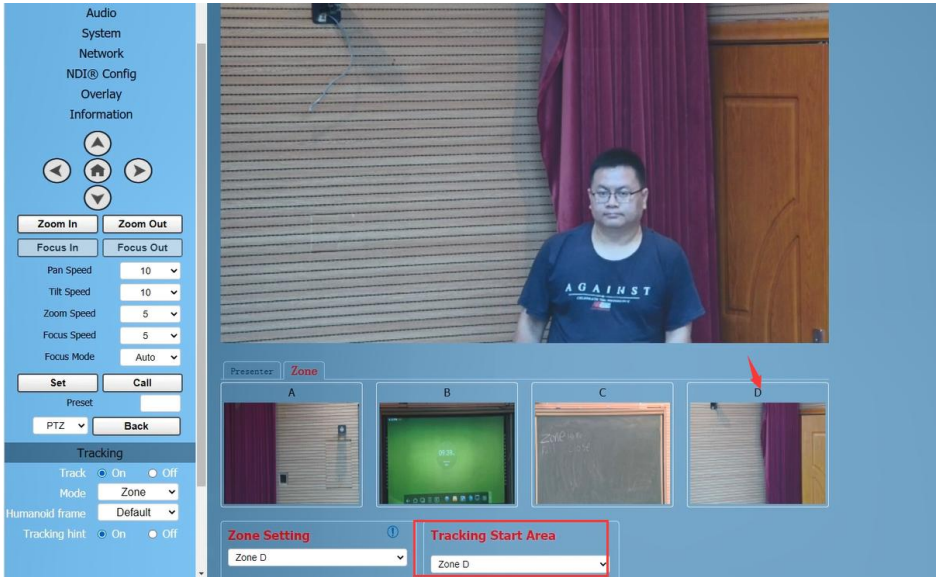

8.2 Remote Control

● Speaker Tracking (Presenter)

The camera default is Speaker Tracking (Presenter), which allows you to check the current settings from the web interface.

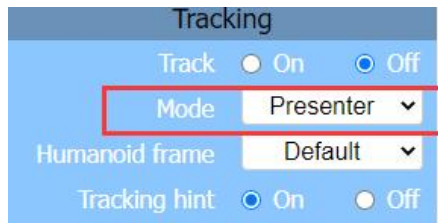

Function: This method can quickly achieve on/off tracking and select tracking targets.

● Single Person Scenario

Press the F3 key on the remote control to start tracking, and press F4 key to exit tracking mode.

When there is only one person in the scene, press the F3 key on the remote control to

start tracking, and the camera will lock the target for direct tracking. The screen is shown in the following figure, indicating that the tracking program has successfully started. Users can press F4 key to exit tracking mode.



● **Multi Person Scenario**

If there are multiple people in the scene, please first press the F3 key on the remote control to start tracking, if there are multiple people in front of the camera, you can press the left and right key on the remote control to select the target to track, and then press the HOME key to confirm. The camera will start tracking. Users can press F4 key to exit tracking mode.



9 Troubleshooting

Image

- The monitor shows no image
 - 1) Ensure that the camera power supply is connected, the voltage is normal, and the power indicator is always on.
 - 2) Turn off the power switch to check that the camera is self-testing.
 - 3) Ensure the cable of video platform and TV that in correct connection.
- Image jitters after the camera is properly connected
 - 1) Ensure that the camera installation is in stable position.
 - 2) Check that any vibrating machinery or object near the camera.
- There is no video image in browser

That do not support IE browser and IE core browser, it is recommended to use Google, Firefox and Edge browsers. The camera video image will be displayed normally.

-
- Unable to access camera through the browser
 - 1) Using PC to access the network to test that the network access can work properly to eliminate the network fault caused by cable and PC virus until the PC and camera can ping each other.
 - 2) Disconnect the network, connect camera with PC separately and reset the IP address of PC if necessary.
 - 3) Ensure that the IP address, subnet mask and gateway settings is correct.
 - 4) Check that the MAC address is conflicts.
 - 5) Check that the web port is modified, the default setting is 80.

- Forget the IP address or login password

The default IP address is: 192.168.100.88; the default username and password are: admin.

Control

- Remote control does not work
- 1) Check and replace with new batteries.
- 2) Ensure that the camera working mode is correct.
- 3) Ensure that the address key of remote control can match the camera.
- Serial port cannot control
- 1) Ensure that the protocol, address and bit rate of the camera are consistent.
- 2) Ensure that the control cable is properly connected.

